

**CKM EXPOSED TEE GRID SYSTEM**

T38/24W

CROSS TEES

600mm: 38x24x0,35mm  
1,200m: 38x24x0,35mm

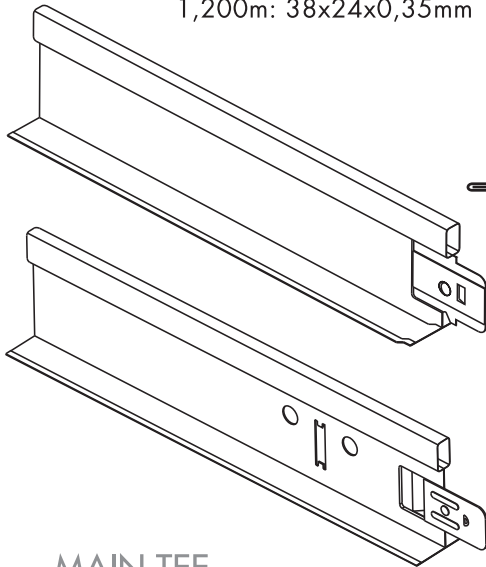

MAIN TEE

3,600m: 38x24x0,35mm

T38/24W FIRE RATED

The Main Tees have punch outs especially designed to collapse under extreme heat thus retaining their integrity. Main and Cross Tee joints overlap allowing them to expand freely

CROSS TEES

600mm: 38x24x0,35mm  
1,200m: 38x24x0,35mm

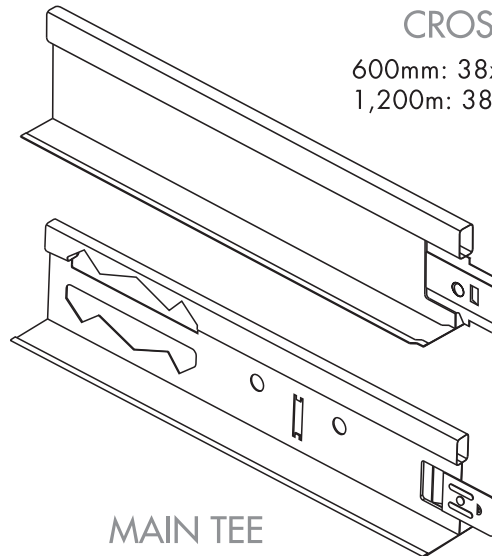

MAIN TEE

3,600m: 38x24x0,35mm

**PERFORMANCE**

**REACTION TO FIRE Class A1**  
**CERTIFICATION**

Our grid system for suspended ceilings which has integrated fire expansion joints, has been fully certified for "Reaction to fire" in several European labs.



Structure according to EN 13964.



Corrosion resistance according to Standards EN 10169.

Harmonised Standards : UNI EN 13964: 2004 + A1: 2006

**QS SPECIFICATION**

The suspension system shall support the ceiling assembly described, with a maximum deflection of 1 /360 of the span. Main Tees and Cross Tees to measure 38 x 24 x 0.35mm. All tees shall be doubled web design with rectangular bulb and manufactured from 0.35mm thick galvanised steel. All tees to be covered with pre-painted white galvanised steel capping. Suspension shall be in accordance with manufacturer's recommendations.

600 x 600mm System

CKM T38/24W Exposed Tee Grid System

Supply and install 3,600m CKM Main Tees at 1,200m centres in one direction and 1,200m CKM Cross Tees at 600mm centres perpendicular to main tees. Fit 600mm CKM Cross tees between the 1,200m Cross tees to form a 600 x 600mm grid. Main Tees are suspended from structure at 1,200m centres with G.M.S Hangers.

